

ENERGY HARVESTING TO POWER AN AUTONOMOUS SENSOR FROM MECHANICAL VIBRATIONS

Adilson J. Cardoso¹, Rafael R. Bravo¹, Lucas G. de Carli^{2*}

¹Federal Institute of Science and Technology of Santa Catarina, Criciúma, Brazil

Rodovia SC 443, km 01, CEP: 88815-096

E-mails: adilson.jair@ifsc.edu.br, bravo@ifsc.edu.br

²Federal University of Santa Catarina

Abstract - This paper describes an approach for harvesting electrical energy from a low-cost piezoelectric element operating at low amplitude vibration to power an autonomous and self-powered sensor. The converter consists of an ordinary piezoelectric buzzer and a steel ball bonded onto it. Furthermore, the design of the CMOS energy processor is presented focusing on the voltage multiplier and for which simulation and measurements results are discussed. This paper presents simple and analytical formulas with high precision to predict the dc output voltage of the voltage multiplier.

Index Terms - autonomous sensor, alternative energy, energy harvesting, microgenerators

1 INTRODUCTION

The micro-sensor networking has been identified as one of the 21 most important technologies of the 21st century (21 ideas for the 21st century, 1999) and as one of 10 emerging technologies that will change the world (10 emerging technologies that will change the world, 2003).

One of the most challenging issues in this area is the development of energy sources that can supply enough power for wireless communication of sensed data. Investigation has focused on batteries and ambient power scavenging to provide power to the autonomous sensor.

In conventional data transmission, sensors are connected by electrical cables to a central data collection (datalogs or other control device) being accessed by a central control. Depending on the distance between the datalogs and control center, the cabling between them becomes impracticable, and the data are collected periodically weekly or more, directly where the sensor is installed.

Fig. 1 (a) shows the topology of the micro-sensor wireless networking and Fig. 1 (b) shows an example of a sensor node. The power can be obtained by vibrations, solar, or even by radio frequency (RF) signal.

In these networks, each node can be equipped with a variety of sensors, such as acoustic, seismic, infrared video cameras, heat, temperature, pressure, etc. These nodes can be organized into clusters in which, at least one of the sensors should be capable of detecting an event in the region, process it and to take decision to perform or not a broadcast of the result to other nodes.

A typical application is the monitoring of industrial machinery, where the vibrations are continuous. In (Roundy,2004), a study of continuous power generated vs lifetime of different source, such as batteries, solar cells and vibrations was performed, and it indicates that for lifetimes of 2 years or longer (as will usually be the case) solar energy and vibrations are the best options because small size batteries can't provide enough energy for wireless sensor nodes (roughly, 100 microwatts average power consumption).

Fig. 1. Wireless sensor networking.

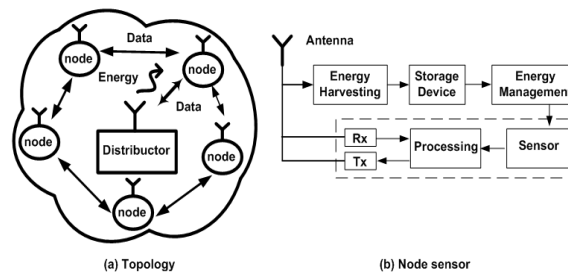

Commercial solar cells have around 20% of efficiency (Barnett,2004), but adequate light sources are not always available. Otherwise, piezoelectric vibration-based systems seem to be an attractive and practical solution, combining good power density and availability of primary source. Efficiency above 50% is easily obtained.

In the industrial environment, the vibrations have acceleration amplitude varying between 0,1 m/s² and 10 m/s² with frequencies between 50 Hz and 120 Hz (g=9,81 m/s²) (Roundy,2004). Thus, the piezoelectric ceramics produce alternate voltages ranging from hundreds of milivolts to a few volts. Table I shows some examples of vibrations sources with peak of acceleration and frequency of vibrations.

The main goal of this work is to focus in the operation for low amplitude vibrations (0.5 g or smaller) harvesting electrical energy for (re)charging a battery or a capacitor.

Tab. I: Peak acceleration and frequency fort several vibrations sources (Roundy,2004), (Beeby,2007).

Ref. (Roundy,2004)	Peak accel. (m/s ²)	Freq.(Hz)
Base of a 5 HP 3-axis machine tool	10	70
Refrigerator	0,1	240
HVAC vents in office building	0,2 - 1,5	60
3CV AC motor with base loosed	9,1	120
Ref. (Beeby,2007)		

Top of the HVAC to several offices	0,31	50
Common compressor	0,15 - 3,2	43 a 109
In the room compressor	0,056	43

2 CIRCUIT DESCRIPTION

The energy scavenging system includes an electric power generator (piezo transducer or buzzer), a storage device (capacitor), and an AC-DC converter. The system is electrically self-powered. An essential characteristic of this energy scavenging circuit is the capability of converting small energy amounts to suitable values of charge for charging a capacitor, which in turn is use it for powering electronic circuits.

A vibrating piezoelectric device generates an AC voltage while electrochemical batteries require a DC voltage, hence the first stage needed in an energy harvesting circuit is an AC–DC rectifier connected to the output of the piezoelectric device. We can use voltage rectifier structure to generate sufficient voltage to the charge control circuit. The traditional structure is showed in the Fig. 4. A challenging task is converting minimum energy amounts to suitably charge a battery or a capacitor, and use it for powering electronic circuits. In this paper, we discuss and simulate a CMOS power processor with the functions mentioned above, analyzing its use in real world applications.

A. Generator:

A full custom design of a piezogenerator using special piezoceramics with high conversion factor is possible but it is a high cost solution. An alternative way is to use a cheap on-the-shelf device (buzzer) maximizing the conversion by using a mass bonded to the piezoceramic (Cardoso,2006). This configuration generates voltages of around hundreds of milivolts at low vibration amplitude (dozens to hundreds of milig).

B. Voltage Multiplier

The majority of industrial machinery produces vibrations with small amplitudes, thus the voltage generated by the piezoelectric ceramic (buzzer) will also be small (150 mV to 1 V). This voltage is insufficient to power an integrated circuit. To resolve this problem, a voltage multiplier can be used to increase the voltage to values compatible with the integrated circuits.

These voltage multipliers can be designed using the classical structure (Fig. 2) (Cockcroft,1932). This topology is more useful to design in an integrated circuit, because the output current is independent of the number of stages, and the efficiency can be

archived with high parasitic capacitance. The parasitic capacitance reduce the voltage in the nodes, and so the voltage in the output.

Fig. 2. Half-wave voltage multiplier structure.

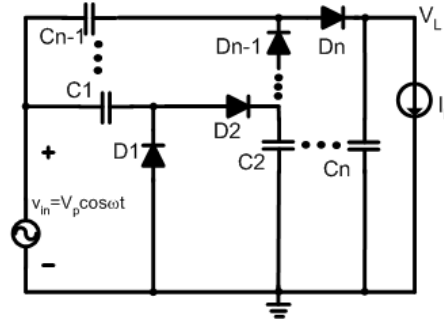

In (Curty,2005) was presented a modification of rectifier of Fig. 3, to operate like as full-wave voltage multiplier.

The principal problem of this topology (Fig. 4) the threshold voltage of the diodes. We can design the diodes in the CMOS technology using transistor MOS to reduce the threshold voltage and design all control in a integrated circuit (Cardoso, Feb. 2010) (Cardoso, Dec. 2010) . How the base of this voltage multiplier is a diode, is important to know their possibilities. In our last publication (Cardoso,2012), we presented a analytical model to predict the output DC voltage of the voltage multiplier, valid to ultra-low input voltage (25 mV to 2 V) with high precision. In this paper we show that, for input voltage bigger than the thermal voltage ($V_p/n\phi_t > 1$) , the dc output voltage is

$$V_L \cong N \left\{ V_p - n\phi_t \ln \left[2(1 + I_L/I_S) \right] \right\} \quad (1)$$

where: N is the number of diode of the voltage multiplier; n is the slope factor; V_p is input peak voltage I_L is the load current, ϕ_t is the thermal voltage, and I_S is the diode saturation current.

In order to check the validity of the model, we simulated and measured the performance of the voltage doubler. The results are shown in the Fig. 3 (a) and (b). The complete work was presented in (Cardoso,2012). For the measurements we employed off-the-shelf 1N4148 diodes and 470 nF capacitors. The experimentally extracted parameters for the diodes are $I_S=4.5$ nA and $n\phi_t=48.5$ mV. In these experiements we use a square wave in the input of the voltage multiplier.

3 EXPERIMENTAL PROCEDURES

A. Generator

The energy converter consists of a steel ball attached onto an ordinary piezoelectric buzzer. The mass bonded weighs 65grams and the buzzer has the following dimensions: metal diameter ($d_m=50\text{mm}$), metal thickness ($h_m=0.3\text{mm}$), piezo diameter ($d_p=28\text{mm}$) and piezo thickness ($h_p=0.20\text{mm}$) (Cockcroft,1932).

Fig. 3. dc output voltage of the half-wave rectifier versus load current for (a) $V_p= 0.3, 0.6, 1.2, \text{ and } 2 \text{ V}$ (b) $V_p=25, 50, 75, 150 \text{ mV}$.

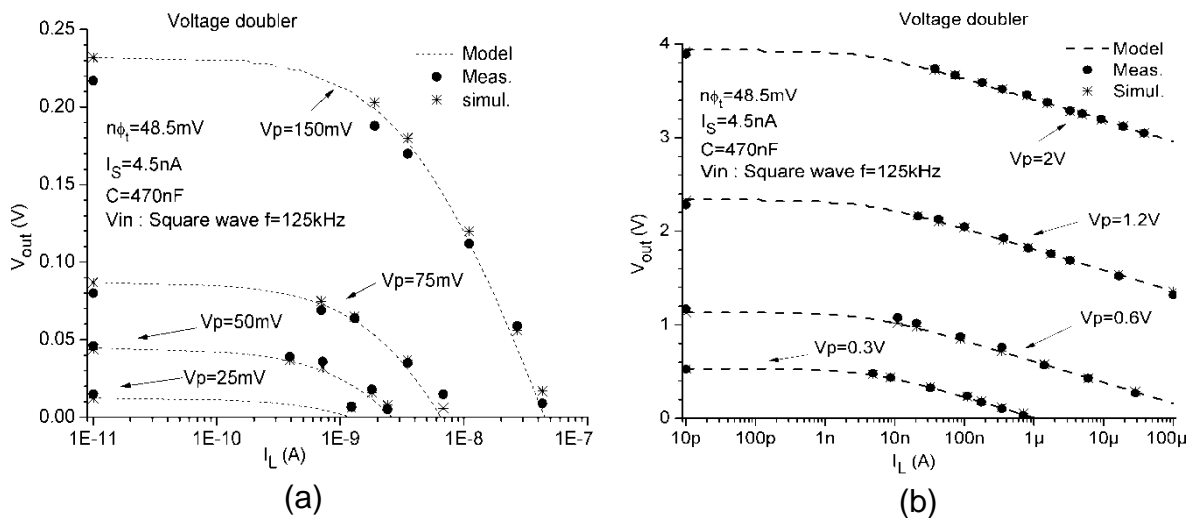

B. Autonomous Sensor

This section will present the prototype of an autonomous sensor with RF development kit eZ430 2500 from Texas Instruments. Fig. XX shows this kit. The hardware includes: Two eZ430-RF2500T target boards based in the MSP430F2274 ultra-low-power processor (with 16MHz of clock frequency) and CC2500 wireless transceiver operating at 2.4GHz, one eZ430-RF USB debugging interface, one MSP430 development tool CD-ROM containing documentation and new development software for eZ430-RF2500, eZ430-RF2500 sensor monitor (code and visualizer). The circuit operates from 1.8V to 3.6Vdc. The sensor is fully autonomous, being powered only by vibrations capted from a 175 liters compressor with a 2 HP motor. In the place (on the compressor) where the piezogenerator was installed, the measured vibration was 10mm/s. At the head of the cylinder, the vibration measured was around 52mm/s.

Fig. 4 shows a photo of the prototype. This photo was taken during a transmission period. We can observe that the DC voltage is 2.2 V. The transceiver consumes around 15mA for the transmission/reception of data and 1.4 μ A in standby mode. The piezoceramic has 25 mm of diameter and the steel ball has weight of 30 grams. The voltage multiplier is the same of the Fig. 3 with three stages (or six diodes/capacitors). The diodes used was 1N4148 and capacitors of 400 nF. In the output was used capacitor of 3 mF to maintain the output voltage between 3.3 Vdc and 2.2 Vdc in the transmission period. The generator is capable of providing 3.3 V for a loading time of 4-5 minutes. To decrease this time you can choose to add generators in parallel (producing more power), or using a transmitter that consume less current during the transmission. We can use diodes with higher saturation current I_0 and lower threshold voltage using Shockley diodes or MOS transistor tied diode in CMOS process.

Several academic studies have transmitters circuits that consume less than 10mA.

Fig. 4. Prototype of autonomous sensor.

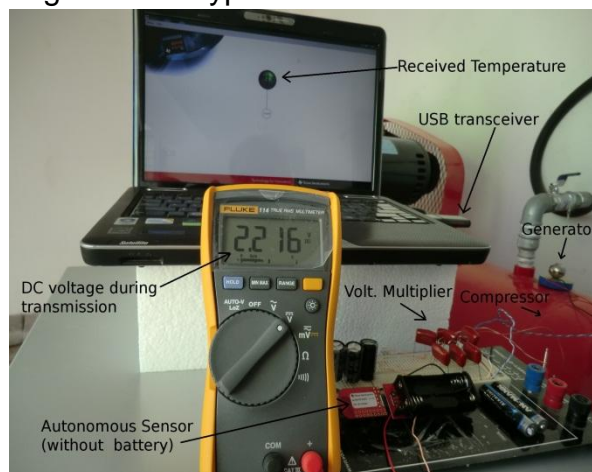

IV DIODES IN CMOS TECHNOLOGIES

Fig. 5 shows the two possible topologies for the MOS transistor connected as a diode. It is important to note that the diode current is composed by the channel current plus the current of the extrinsic diode. The disadvantage of the MOS transistor in the usual connection, with the bulk (B) tied to the source (S) (Fig. 4a), is the high reverse current. In effect, the reverse current of the device in Fig. 8a is due to the direct current in the extrinsic diode which increases exponentially with the increase of the magnitude of the reverse bias. To avoid the high reverse current of the conventional MOS diode, the

DTMOS (Dynamic Threshold voltage MOSFET) connection can be used. In effect, in the DTMOS connection of the MOSFET, with the gate (G) tied to the substrate (Fig. 4b), the channel and the extrinsic diodes are in parallel. The DTMOS connection can be used for p channel transistors in an n-well process or for the nMOS transistors in p- or triple-well processes. To model the MOS diodes, we will use, for the sake of simplicity, the weak inversion model, which is appropriate for low voltage operation

The drain to source current is expressed (Vittoz,1977) by

$$I_{DS} = \frac{W}{L} I_o e^{\frac{V_{GB}-V_T}{n\phi_t}} \left[e^{\frac{-V_{SB}}{\phi_t}} - e^{\frac{-V_{DB}}{\phi_t}} \right] \quad (3)$$

$$I_o = \mu_0 n C'_{ox} \phi_t^2 e^{-1} \quad (4)$$

where: V_T : threshold voltage; n is the slope factor, C'_{ox} is the oxide capacitance per unit area.

Fig. 5: Transistor MOSFET conected as diode. (a): Standard conection S=B; (b) Conection DTMOS.

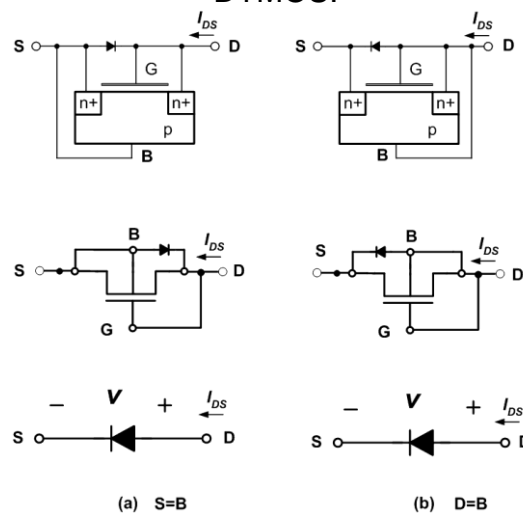

4.1 Voltage multiplier - Topology with MOS transistor

Fig. 6 shows the topology of the voltage multiplier using MOS transistor connected as diode. In recent technologies such as 90nm, the threshold voltage is approximately 250mV. It is also possible to use transistors zeroVT in which the threshold voltage is lower than 100mV. The threshold voltage in common diodes is much greater.

Fig. 6. Topology of voltage multiplier with MOS transistor tied diode.

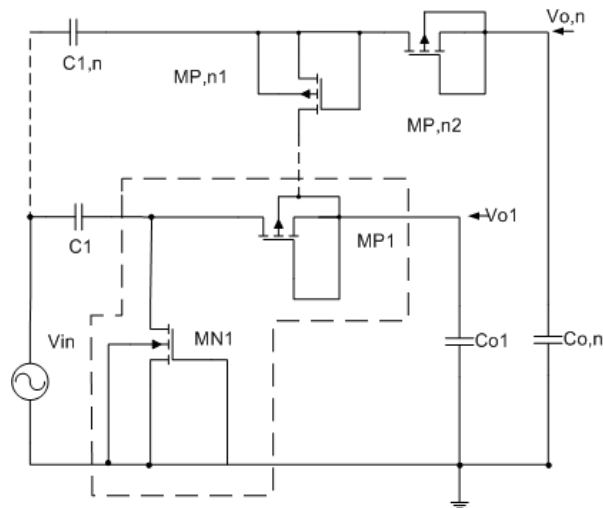

5 CONCLUSIONS

In this paper was analyzed an energy harvester to power an autonomous and self-powered sensor, consisting of a piezoelectric generator and a voltage multiplier. The generator was able to power the sensor to transmit the temperature measured in periods of 4-5 minutes. The piezoelectric generator is assembled with a low-cost piezoelectric (buzzer) and uses mechanical vibrations as input. Its response was measured as a function of the input vibration amplitude and output load. In this paper the simple and analytical formulas with high precision to predict the dc voltage of the voltage multiplier was presented and compared with measurements. In this work also was presented the MOS transistor connected as a diode for use in a voltage multiplier within an integrated circuit. Thus, various other blocks (charge controller, transceiver, etc) may be designed together into a integrated circuit to improve efficiency to the converter.

ACKNOWLEDGMENT

The authors gratefully acknowledge the contribution of Institute of Science and Technology of Santa Catarina and to CNPq for the financial support.

References

- 21 ideas for the 21st century** . Business Week, pp. 78-167, August 1999.
10 emerging technologies that will change the world. Technology Review, vol. 106, pp. 78-167, February 2003.

Roundy S. Energy Scavenging for Wireless Sensor Networks. Kluwer Academic Publisher, New York – EUA, 2004.

Barnett, A. **Solar Power Program.** University of Delaware. <http://www.solar.udel.edu/research.html>, 2009

Beeby, S. P., Torah, R. N., Tudor, M. J. P., Glynn-Jones, T., O'Donnell, C. R. Saha, and Roy, S. . **A micro electromagnetic generator for vibration energy harvesting.** Journal of Micromechanics and Microengineering, 2007, Vol. 17. No. 7. pp.1257–1265.

Cardoso A. J. , Rodrigues C. R., Pippi. R. S. **Energy Harvesting Based on a low-cost piezoelectric acoustic transducer.** 49th IEEE International Midwest Symposium, 2006.

Cockcroft ,J.D. and Walton, E.T. **Production of high velocity positive ions.** In Proc. Roy. Soc, 1,932, pages 619–630

Curty, J. P., Joehl, Krummenacher, N., Dehollain, F. C. and Declercq, M. **A model for uPower Rectifier Analysis and Design.** IEEE Transactions on Circuits and Systems I, 2005, Vol. 52, No. 12, pp.2771–2779.

Cardoso, A .J., Galup-Montoro, C. and Schneider, M. C. (2010). **CMOS Rectifier Design for Energy Harvesting based on Vibrations.** IBERCHIP XVI Workshop, Feb. 2010), Iguçu Falls, pp. 241-245

Cardoso, A. J., Galup-Montoro, C. and Schneider, M. C. **Design of very low voltage CMOS rectifier circuits.** IEEE 2010 Circuits and Systems for Medical and Environmental Applications. Workshop (CASME), Mérida, Mexico, Dec. 2010

Cardoso, A. J., Montoro, Galup-Montoro, C. and Schneider, M. C. and Carli, L. G. (2012). **Analysis of the rectifier circuit down to its low-voltage limit.** IEEE Transaction on Circuit and System - I. vol.59 , n.1 , pp. 106-112, Jan, 2012

Vittoz, E. and J. Fellrath. **CMOS analog circuits based on weak inversion operation.** IEEE Journal of Solid State Circuits, 12(3):224–231, 1977.